



Abraham S. Laboratories in Antimicrobial Resistance (AMR) Control and A Practical Approach for Operationalising Action Plan in the Animal Laboratory Sector. (Viewpoint). JGPOH 2025, posted: 14.02.2025. DOI: 10.61034/JGPOH-2025-02

Viewpoint

Laboratories in Antimicrobial Resistance (AMR) Control and A Practical Approach for Operationalising Action Plan in the Animal Laboratory Sector

Swapna Susan Abraham¹

¹ State Institute for Animal Diseases, Department of Animal Husbandry, Kerala, India.

Recommended citation:

Abraham, SS. Laboratories in Antimicrobial Resistance (AMR) Control and A Practical Approach for Operationalising Action Plan in the Animal Laboratory Sector. JGPOH 2025. DOI: DOI number by publisher, Website: by publisher.

Corresponding author:

Dr. Swapna Susan Abraham, Deputy Director (Rtd), State Institute for Animal Diseases, Department of Animal Husbandry, Kerala. India

E mail: swapnasusan2003@yahoo.co.in

Phone: +91 9446557186



Abraham S. Laboratories in Antimicrobial Resistance (AMR) Control and A Practical Approach for Operationalising Action Plan in the Animal Laboratory Sector. (Viewpoint). JGPOH 2025, posted: 14.02.2025. DOI: 10.61034/JGPOH-2025-02

Abstract

AMR is a significant public health issue of 21st century. The issue is complex with multi-sectoral involvement calling for One Health approach. There is a global call for AMR control and the issue is highlighted in multiple high level global platforms like WHO, FAO and WOAHA, providing guidelines and action plans. Laboratories have a key role to play in combating AMR. Despite the availability of strategic documents and action plans, implementation at the field level faces many challenges in LMICs due to the lack of supporting operational guidelines and disparity in disciplinary capacity and priorities. This model proposal allows a sequential operational process to implement action plan which can be adopted at the institutional, departmental or sector level. It has been prepared based on the current Indian laboratory scenario in animal sector. Though it is designed mainly for animal laboratory sector, the author's expertise domain, it is not unique to the sector and is flexible for expansion and modifications according to local settings.

Keywords: action plan, antimicrobial resistance, laboratories, surveillance, network, operationalising.

Conflict of interests: None declared.

Financial disclosure: None declared.

Data availability: All relevant data are within the paper and its supporting Information files.



Introduction

Antimicrobial resistance has emerged as a significant public health issue globally posing substantial challenges in terms of surveillance and activities to combat AMR. As usual, the impact is profound in developing countries of Asia and Africa. The reasons are multiple. Besides the high burden of infectious diseases, antibiotics are scarce resources in developing countries and are often unregulated (1). The AMR problem is complex with multi-sectoral involvement calling for a “One Health” module to address it. The issue is highlighted as a priority in several high-level global platforms such as WHO, FAO and WOA. There is a global call for AMR control with World Health Assembly launching Global Action Plan in 2015 (2). As a responsible partner, India came out with a national action plan in 2017 (3), and many states have followed suit by developing state-level action plans (4).

Laboratories have a key role to play in achieving the objectives of these strategic documents. They are critical partners in combatting AMR by identification of the pathogen, through AMR/AST testing and characterization of the pathogenic bacteria, and creating the data base (5). Valid laboratory surveillance data are needed to estimate the burden of AMR, understand trends, identify drivers, measure impact, and develop mitigation strategies. Laboratory surveillance of AMR is more likely to be successful when implemented as tailored to the local level of capacity. This document briefly discusses how a laboratory is integrated in the AMR mitigation pathways (Figure 1) and proposes a sequential operational process to implement action plan which can be adopted at institutional, departmental or sector level.

Laboratory techniques in AMR

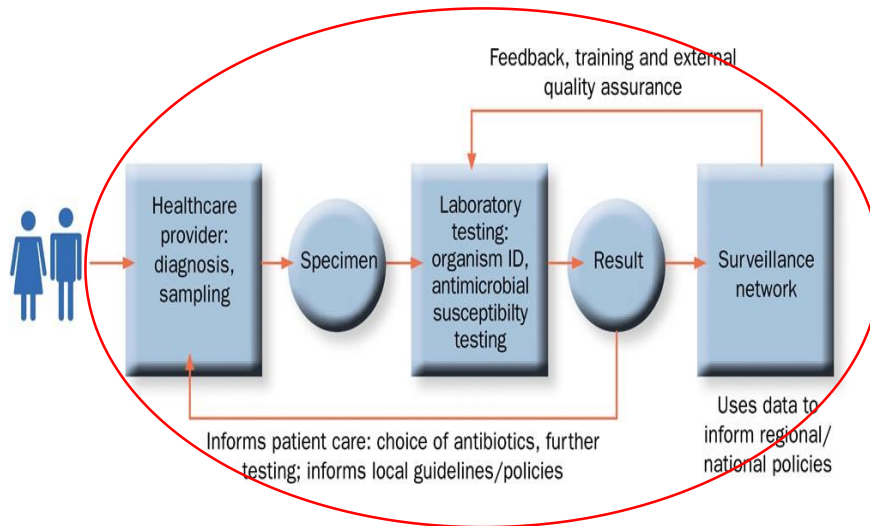
Phenotypic and genotypic methods are used to detect and characterize AMR (6). Culture based conventional techniques such as disc diffusion and measurement of minimum inhibitory concentration (MIC) are the most common for identifying sensitivity and resistance of a pathogen to antibiotics. Along with these traditional methods, rapid and efficient methods are being employed such as automated system (eg. Vitek, MALDI-TOF-MS) and various E tests. These methods offer higher throughput and demand lesser skill. These methods are efficient for initial screening and therapeutic support.

Besides phenotypic characterization, molecular tests such as PCR for detection of gene, genomic sequencing (partial and whole genome) are also in use in laboratories for genomic characterization. These novel techniques cannot fully replace traditional methods as they can't differentiate viable and nonviable or between pathogenic and non- pathogenic bacteria always (7). Moreover, they are unable to generate quantitative AMR data which is essential for therapeutic purpose. However, both phenotypic and genotypic methods are essential for a complete insight into resistome.



How can a laboratory integrate into the AMR containment system

Figure 1: Schematic illustration of laboratory integration in AMR containment System (Courtesy. Seale et al., 2017[8])



Improving awareness and understanding: Communication from laboratories is evidence based. Therefore, laboratory professionals are in an excellent position to educate clinicians and other healthcare professionals. They can create the opportunity to discuss specific cases and issues. They can educate patients, the public, the media and policy makers about the causes, mechanisms of spread and evolution of AMR.

Strengthen knowledge and evidence through surveillance: Laboratory testing helps to identify the etiology, select the most appropriate agent and to monitor the efficacy of the treatment. Only through laboratory surveillance, can the true impact, burden and magnitude of the problem be determined. They play a key role in the safety testing of animal food products through antimicrobial residue analysis. Surveillance and laboratory testing are critical to the implementation of alternatives to antibiotics. Laboratories provide the economic evidence that is essential for political commitment and sustainable investment.

Labs in IPC (Infection, Prevention, Control) System: The laboratory plays crucial role in IPC activities in hospitals, intensive care units and operating rooms which are common areas for nosocomial AMR infections. Laboratories assist in the identification of resistant infections and source tracing. Regular in-house IPC monitoring systems require laboratory support. Laboratories also help to effectively implement biosecurity procedures in farms and food processing centres.



Optimizing Antimicrobial Use: By identifying the etiology, a laboratory helps the clinician to decide whether the antibiotic is needed at all. They help to provide targeted and evidence-based therapy tailored to the individual by helping to select the correct drug, dosage and duration. This helps to reduce antibiotic usage (AMU) and antibiotic consumption (AMC).

Research & Innovations: Research into strategies, tools and options to combat AMR and infections requires laboratory support for development, evaluation and implementation. Laboratory research focuses on different aspects of resistant pathogens and their spread that are essential for developing control and prevention strategies.

Collaborations: Being a multidisciplinary and transboundary issue, collaboration is the backbone of any AMR control program. Laboratory collaborations for research, integrated surveillance and development at regional or global level enhance the output. The scope for collaboration for laboratories is immense and can be mainly for diagnostic services, surveillance, and research and developments.

Policy formation: Laboratories provide evidence-based data that be the basis for policy decisions by governments, health care institutions and decision makers.

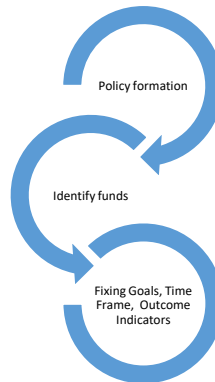
Model Operational Road Map for Implementing AMR Action Plan in the Laboratory Sector

WHO has launched Global Action Plan in 2015 and many general guidelines to address antimicrobial resistance. But the implementation at field level in LMICs faces many challenges due to lack of supporting operational guidelines and disparity in disciplinary capacity and priorities. This document proposes a sequential operational process to implement action plan which can be adopted at institutional, departmental or sector level. Some of the actions listed should be implemented in parallel. It has been prepared based on the current Indian laboratory scenario in animal sector. It is prepared in line with the conceptual strategies of global and national health organizations and after reviewing the roles of the laboratories in AMR mitigation. Veterinary laboratories are mostly diagnostic laboratories attached to animal husbandry departments, veterinary universities, and recently booming private clinics. Disease surveillance, monitoring, and research are the general mandates.

STEP 1: PREPARATORY STAGE: Formulating an in-house policy, identifying goals (short, mid and long term), and setting a time frame forms the main part of preparation (Figure 2). A time frame of 4-6 years is more practical. For any system to be sustainable, political commitment and continuous funding are crucial. Addressing policy matters as and when necessary, is critical. Outcome indicators should also be finalized while planning.

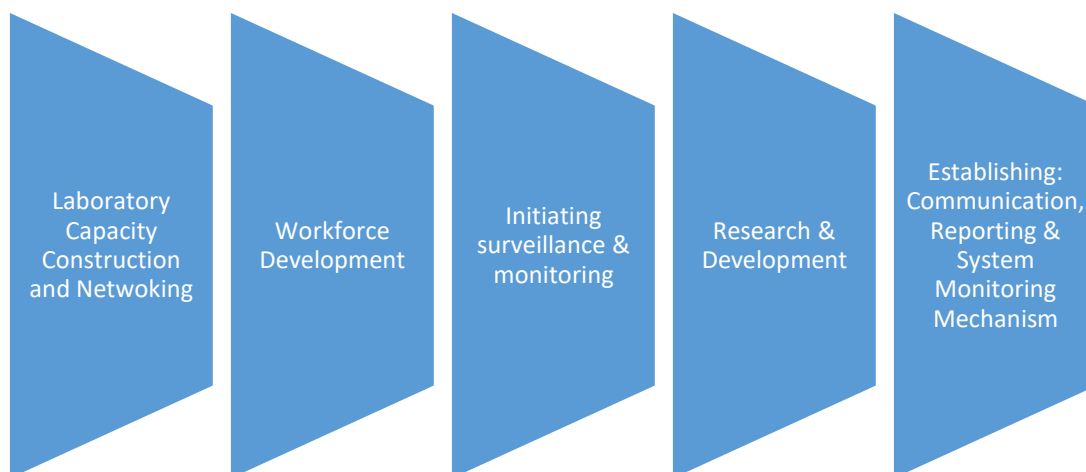


Figure 2: Graphical Abstract: Preparation



STEP 2: IMPLEMENTATION STAGE: Implementation can be planned in phased manner. It may be more practical to plan in 3- 4 phases depending on resources and local conditions. Key areas for action in the laboratory sector are laboratory capacity construction, workforce development, surveillance and monitoring, research and development, and reporting and communication (Figure 3).

Figure 3: Graphical Abstract: Implementation



I. Laboratory Capacity Construction and Networking

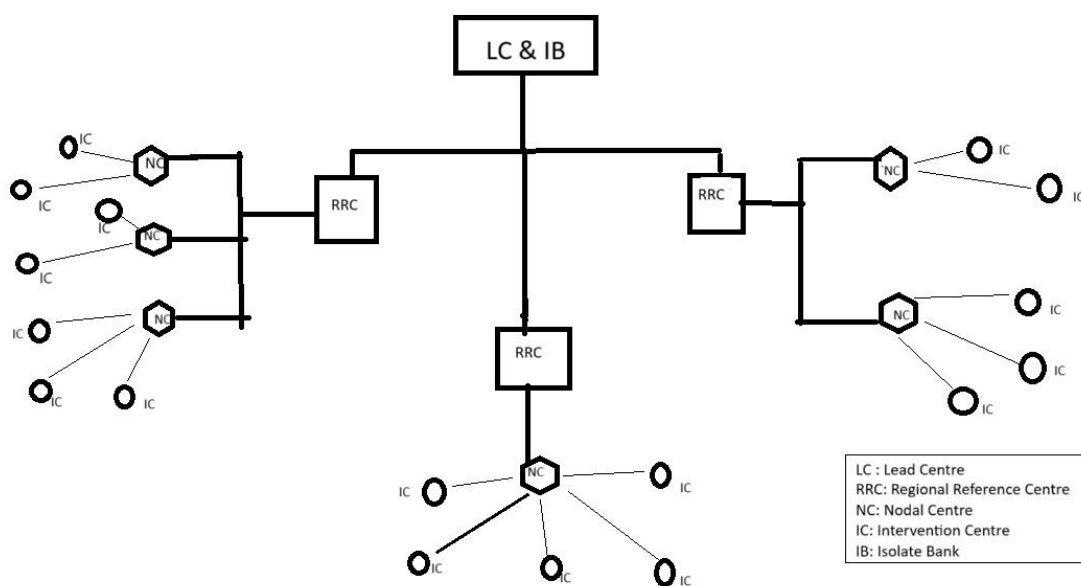
Laboratory capacity construction and networking should be planned in phased manner depending upon resources available in a step-wise manner.



- **Capacity assessment of existing laboratories:** Functioning microbiology laboratories in the region should first be assessed for their capacity to perform AMR laboratory testing.
- **Selection of laboratories:** Laboratories which are routinely conducting antibiotic sensitivity testing and characterization can be selected for the first phase networking.
- **Networking of selected laboratories:** Official networking should be established between the laboratories with clear cut reporting and communication formalities.
- **Designating AMR reference laboratories:** Based on the infrastructural strength, different designations and hierarchy system such as sample collection centre, intervention centre, nodal centre, reference lab, lead centre, genome bank, isolate bank, residue analytical lab, etc should be established (Figure 4). This is essential for the smooth functioning of the network.
- **Hub-and-Spoke Operations in the network:** Clear reporting and communication formalities should be outlined for the efficient functioning of the network in terms of periodicity and type of reporting as well as agreement on sharing of data, samples and materials. Network operations can be planned as a single or multiple hub-and-spoke model, depending on the number of laboratories in the network (9).

There should be continuous efforts and investment for strengthening of more laboratories and expanding the network in a phased manner.

Figure 4: Graphical Abstract: AMR Lab Network: Hub-and-Spoke Model





II. Workforce Development, Educational Outreach and Developing SOPs

Laboratory staff are frontline AMR responders. Recognizing the value of training in building competency and creating a registry, the emphasis on workforce development cannot be overstated. Staff shortage, competing priorities, lack of visibility, and perceived lack of career advancement are some of the barriers laboratories face. An ongoing mechanism to enhance understanding and skills, ideally an “AMR training centre”, should be established.

- **Defining areas for skill development:** Minimum training areas for laboratory professionals include techniques for AMR detection and characterization, data collection and analysis, surveillance methods, participation in networks, and AMR dynamics and epidemiology.
- **Designing training levels, modules and calendar:** Trainings should range from sensitization training in step-up-manner to advanced training. It should include wet-lab training and workshops.
- **Maintaining a registry of trained workforce:** Retention of trained staff is a challenge for most laboratories. Policy changes may become necessary in government sectors.
- **Developing SOPs and Guidelines:** Harmonization in protocols and procedures across the laboratories are essential for generating quality data. SOPs should be developed by each sector for testing protocols, reporting channels, system reviews, evaluation criteria, etc., while addressing disciplinary differences.
- **Educational outreach:** Laboratory professionals should also participate in educational programs for the general public, clinicians and policy makers. The envisaged “AMR Training Centre” can channel this.

III. Surveillance and Monitoring: (10) Once the laboratory network has been outlined and channeled, and initial sensitization has been imparted, properly designed and planned integrated surveillance programs should be initiated.

- **Passive surveillance:** Regular self- reporting by laboratories with relevant data in the established network is the first step to make the network work and is relatively inexpensive to manage. It can be further improved for quality in due course.
- **Active surveillance:** Passive surveillance data are unlikely to be complete, timely and representative. Therefore, AMR-centric active surveillance should begin in each participating laboratory. But it comes at a cost. So, depending on resources and capacity, each member laboratory can enable it at different levels.
- **Sentinel surveillance system:** Sentinel units (active or passive), if feasible can be established.
- **Genomic surveillance:** At the very least, reference labs in the network should use genotypic tools that will be helpful in designing long-term intervention strategies and for research back- up.
- **Laboratory information system (LIS):** Automated transmission can facilitate real-time reporting and more useful analysis (11). It can easily be linked to external networks



(national or global or multisectoral). Again, different laboratories can enable it at different levels.

- **AMR Bank:** The creation of a repository of resistant isolates and a genomic data base should also begin once the laboratory network is up and running.
- **Residue monitoring:** Monitoring of antibiotic residues in animal food products and environmental samples is essential to understand the actual burden and to observe the impact of applying various control measures. It is necessary to identify or strengthen at least one laboratory for residue analysis in the network.

IV. **Research @ AMR Laboratories:** Research and innovations are critical to combating AMR and laboratories are an integral part of this effort.

- **Identify research priorities**
- **Identify and mobilise funds**
- **Initiate research projects** preferably collaborative research
- **Create platform for publicising the research findings:** Periodic AMR conclaves or AMR research days can facilitate deliberations on research findings.

V. **Reporting & Communication:** For the system to work effectively, timely communication and reporting as outlined in the policy document should work. This is important to address timely issues, policy changes, and to secure resources.

- **Constitute a monitoring committee** with representatives from all laboratory partners, stakeholders and policy makers: Regular periodic review of operations facilitates smooth running of the network.
- **Platforms for AMR knowledge dissemination dialogues:** Platforms should be created at each level of the laboratory network for regular discussions and deliberations among working partners.
- **Liaison with other sectors:** Once the formalities of intra-sectoral networking have been completed and put in place, external links with higher platforms (national/global) and other sectors should be established. AMR is a multidisciplinary issue and no sector alone can address it alone.

Conclusion: Nearly ten years have passed since WHO launched its global action plan. It is high time to move from awareness to action. Laboratories play a pivotal role in AMR mitigation efforts across all sectors (12). The protocol presented here for implementing AMR action plan in the laboratory sector is not exhaustive and is flexible for expansion and modification according to local settings. Although it is primarily designed for animal laboratory sector, the author's area of expertise, it is not unique to this sector.



Abraham S. *Laboratories in Antimicrobial Resistance (AMR) Control and A Practical Approach for Operationalising Action Plan in the Animal Laboratory Sector. (Viewpoint). JGPOH 2025, posted: 14.02.2025. DOI: 10.61034/JGPOH-2025-02*

References

1. Hart CA, Kariuki S. Antimicrobial resistance in developing countries. *BMJ*. 1998 Sep 5;317(7159):647-50. doi: 10.1136/bmj.317.7159.647. PMID: 9727995; PMCID: PMC1113834.
2. World Health Organization: Global Action Plan on Antimicrobial Resistance. 2015; (accessed 20.11.24).
3. Government of India. National Action Plan on Antimicrobial Resistance. <https://ncdcmohfw.gov.in/wp-content/uploads/2024/03/File645-45pdf>
4. Kerala Antimicrobial Resistance Strategic Action Plan (KARSAP). <https://cdn.who.int/default-source/searo/india/antimicrobial-resistance/karsp-keralaantimicrobialresistancestrategicactionplan.pdf>.
5. Musa K, Okoliegbe I, Abdalaziz T, Aboushady AT, Stelling J, Gould IM. Laboratory Surveillance, Quality Management, and Its Role in Addressing Antimicrobial Resistance in Africa: A Narrative Review. *Antibiotics (Basel)*. 2023 Aug 14;12(8):1313. doi: 10.3390/antibiotics12081313. PMID: 37627733; PMCID: PMC10451735.
6. Palmer GH, Buckley GJ. *Combating Antimicrobial Resistance and Protecting the Miracle of Modern Medicine*. Washington (DC): National Academies Press (US); 2021 Oct 20.4, Strengthening Surveillance. Available from: <https://www.ncbi.nlm.nih.gov/books/NBK577274>
7. Amin MA, Pasha MH, Hoque MN, Siddiki AZ, Saha S, Kamal MM. Methodology for laboratory-based antimicrobial resistance surveillance in animals. *Vet World*. 2022 Apr;15(4):1066-1079. doi: 10.14202/vetworld.2022.1066-1079. Epub 2022 Apr 25. PMID: 35698528; PMCID: PMC9178567.
8. Seale AC, Gordon NC, Islam J et al. AMR Surveillance in low and middle-income settings - A roadmap for participation in the Global Antimicrobial Surveillance System (GLASS) [version 1; referees: awaiting peer review] *Wellcome Open Research* 2017, 2:92 (doi: 10.12688/wellcomeopenres.12527.1).



Abraham S. *Laboratories in Antimicrobial Resistance (AMR) Control and A Practical Approach for Operationalising Action Plan in the Animal Laboratory Sector. (Viewpoint). JGPOH 2025, posted: 14.02.2025. DOI: 10.61034/JGPOH-2025-02*

9. Pascale Ondo, Geetanjali Kapoor, Yewande Alimi, Edwin Shumba, Gilbert Osen, Michael Maina, et al. Bacteriology testing and antimicrobial resistance detection capacity of national tiered laboratory networks in sub-Saharan Africa: an analysis from 14 countries, *Lancet Microbe* 2025;6:100976. published online December 2024. www.thelancet.com/microbe Vol 6, 2025
10. Comelli A, Zanforlini M, Mazzone A, Pedroni P, De Castro U, Scarioni S et al. How a laboratory-based antimicrobial resistance (AMR) regional surveillance system can address large-scale and local AMR epidemiology: the MICRO-BIO experience. *Front Public Health*. 2024 Feb 12;12:1341482. doi: 10.3389/fpubh.2024.1341482. PMID: 38410663; PMCID: PMC10895007.
11. FIND. AMR Laboratory Scorecard User guide. https://www.finddx.org/wp-content/uploads/2023/02/20210801_rep_amr_scorecard_human_001_FV_EN.pdf
12. Lile Malania, Inge Wagenaar, Onur Karatuna, Arjana Tambic Andrasevic, David Tsereteli, et al. Setting up laboratory-based antimicrobial resistance surveillance in low- and middle-income countries: lessons learned from Georgia, *Clinical Microbiology and Infection*, Volume 27, Issue 10, 2021, Pages 1409-1413, ISSN 1198-743X, <https://doi.org/10.1016/j.cmi.2021.05.027>.

© 2025, Abraham; This is an Open Access article distributed under the terms of the Creative Commons Attribution License CC BY-NC-ND 4.0 (<https://creativecommons.org/licenses/by-nc-nd/4.0/>).